

TRANSPORTKETTINGEN

Hollebout - Draagkettingen - MCT met verhoogde zijplaten

DIN 8168

ISO 1977

Ketting nummer	Steek p [mm]	Inwendige breedte b1 [mm]	b2 [mm]	b3 [mm]	Pen- diameter d1 [mm]	Bus- diameter d2 (O) [mm]	Rol- diameter d4 (B) [mm]	Hollebout boring d6 [mm]
MCT 28	63 80 100 125 160	20	28	28,3	13	17,5	36	8,2
MCT 56	80 100 125 160 200 250	24	33	33,3	15,5	21	50	10,2
MCT 112	100 125 160 200 250 315	32	45	45,5	22	29	70	14,3
MCT 224	160 200 250 315 400 500	43	60	60,6	31	41	100	20,3

TRANSPORTKETTINGEN

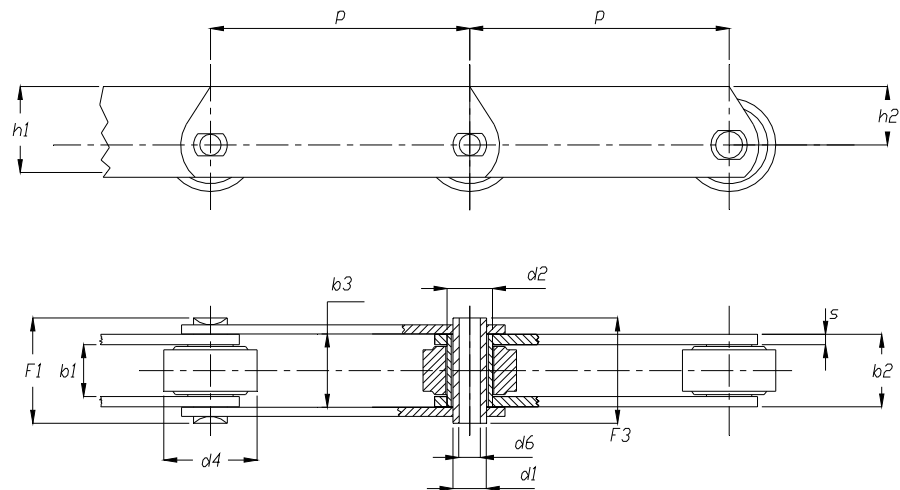

Pen- lengte F1 [mm]	Pen- lengte F3 [mm]	Plaathoogte		Plaat dikte s [mm]	Scharnierend opp. [cm ²]	Maximale Oppervlakte- druk [N/cm ²]	Breuk belasting [kN]
		h1 [mm]	h2 [mm]				
40,6	40,6	35	22,5	3,5	3,64	1100	28
46,6	46,6	50	32,5	4	5,11	1560	56
63,8	63,8	70	45	6	9,90	1610	112
82,9	82,9	100	65	8	18,60	1720	224